

GVK15

Combined Valve Unit for Gas With
G1/2" Connection for burners up to
70 kW



BRAHMA

GENERAL DESCRIPTION

GVK15, suitable for working pressure up to 150mbar, consists in 2 electronic safety class A valves with G1/2" connections, normally closed, quick opening.

The combined gas valve can work directly with continuous current (V_{DC}) or by means of a rectifying circuit with on board connection (V_{RAC}).

FEATURES

- EC- type certification in accordance with the new European Gas Appliances Regulation (EU) 2016/426 (GAR);
- conformity to EC Low-voltage directive 2014/35/EU
- In compliance with EN 126:2012 (European standard for multifunctional controls for gas burning appliances)

OPTIONS

- Pressure test points upstream and downstream.
- Pilot burner connection G1/4F available on the opposite side of the coil connection terminals.

TECHNICAL FEATURES

- Class: A+A
- Group: 2
- Nominal Diameter: DN15
- Type of gas: 1st, 2nd and 3rd family
- Supply voltage: 12 $V_{DC-VAC-V_{RAC}}$
24 $V_{DC-VAC-V_{RAC}}$
110 $V_{DC-VAC-V_{RAC}}$
230 $V_{DC-VAC-V_{RAC}}$
- Max. consumption: 78 mA (230 V_{DC})
- Max. power: 70 kW
(with $\Delta P = 5$ mbar)
- Min. adjustable power: ≥ 6 kW
- Flow rate: 5 m^3/h
($\Delta P = 2.5$ mbar)
(r.d. 0.5545 kg/dm^3)
- Pressure range: 0 ÷ 150mbar
- Operating temperature: - 10 °C ... + 60 °C
- Opening time: ≤ 1 s
- Closing time: ≤ 1 s
- Mounting position: horizontal and vertical not upside down
- Connections: UNI ISO 228/1 G1/2
- Max. tightening torque: 50 Nm
- IP rating: IP40
- Filter: inlet,
- Body: die casting aluminum
- Inner passage diameter: 15 mm
- Weight: 735g
- Pressure test point: upstream and downstream

DIRECTIONS FOR INSTALLATION AND MAINTENANCE

- This valve is a safety appliance and should not be modified. The manufacturer's responsibility and guarantee are invalidated in case the device is tampered with by the user.
- Respect the applicable national and European standards (e.g. EN 60335-1) regarding electrical safety.
- Make sure that no foreign bodies have entered the valve body.
- Assemble the valve to the installation in such a way the arrow on the valve body has the same direction as the fuel flow.
- When assembling the valve to the installation piping, avoid twisting on the sheath but always use a hexagonal wrench on the valve body.
- Make sure that the maximum fuel input pressure never exceeds the value appearing on the product label.
- All operations (installation, maintenance, etc.) must be carried out by a qualified technician.
- Before any connection operation, completely isolate the system from power supply (multi-pole disconnection). Place the system safely to avoid accidental switch-on and make sure there is no voltage. If the system is not switched off, there is a risk of electric shock.
- During and after any operation (installation, maintenance, etc.), make sure that the type and code are the ones provided, check the correct functioning and the internal and external thickness of the valve.
- In the event of a fall or impact, the valves must not be started, as safety functions may be compromised even if no damage is visible to the outside.
- Faulty valves or damaged must be unplugged from power supply and cannot be used.
- The valve has a designed lifetime* based on the endurance tests in the standard EN 161. A summary of the conditions has been published by the European Control Manufacturers Association (Afecon) (www.afecor.org). The designed lifetime is based on use of the valve according to the manufacturer's technical notes. After reaching the designed lifetime in terms of the number of burner startup cycles, or the respective time of usage, the valve has to be replaced by authorized personnel.
- * The designed lifetime is not the warranty time specified in the Terms of Delivery.

CONSTRUCTION

GVK15 is equipped with pressure test point upstream and/or downstream of the group

The opening of both cores is quiet as muffled by an anti-noise ring.

In V_{RAC} version a varistor built in rectifier circuit board protects the valve group from voltage spikes that can be generated into the power supply network, caused for example by discharges such as lightning.

ACCESSORIES

GVK15 It is also possible to have the predisposition for the fixing of a pipeline on the right or on the left in order to feed a pilot, positioned on the opposite side of the coil connection terminals. The group, in V_{RAC} version, can be equipped with a rectifier circuit in Graetz bridge with three-way connector type CJT C6351HF - 3P or with plug DIN 43650 in the simultaneous or separate opening version.

OVERALL DIMENSIONS

GVK15*1L*D*C

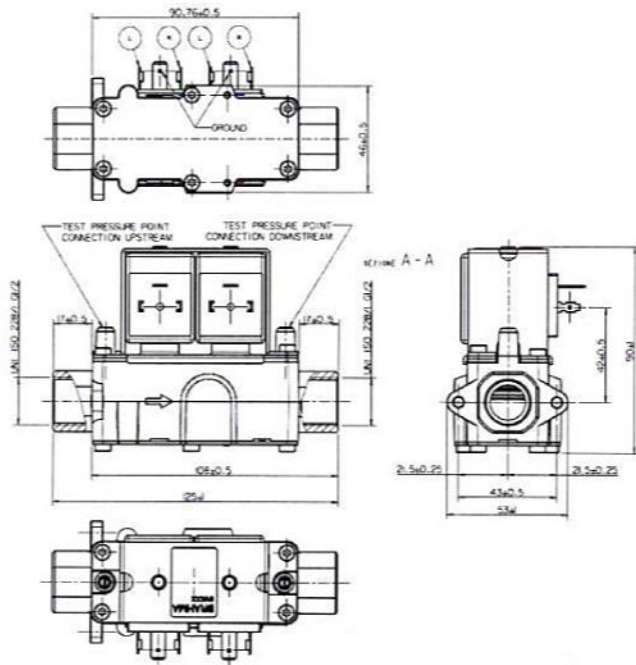

GVK15*2LPD*C

(Pilot outlet version)

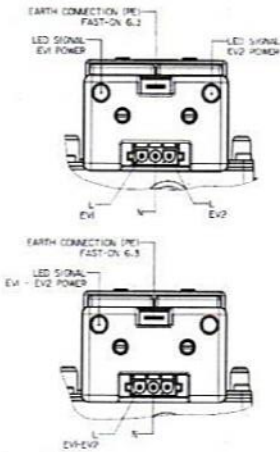
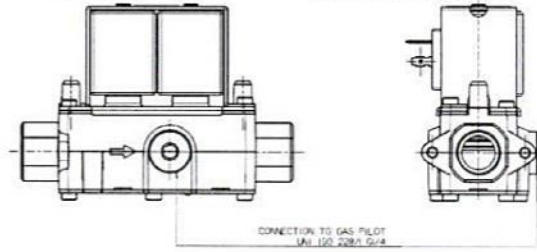

ELECTRICAL CONNECTION
A GRAETZ BRIDGE
OPENING INDEPENDENT
(Version with pilot connection)

CONNECTOR
CJT C6351HF-3P

PLUG
DIN 43650

ELECTRICAL CONNECTION
A GRAETZ BRIDGE
OPENING SIMULTANEOUSLY
(Version without pilot connection)

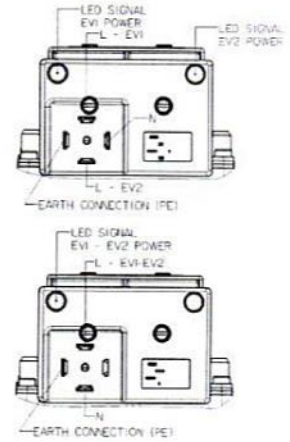

FEATURES

Valve group denomination

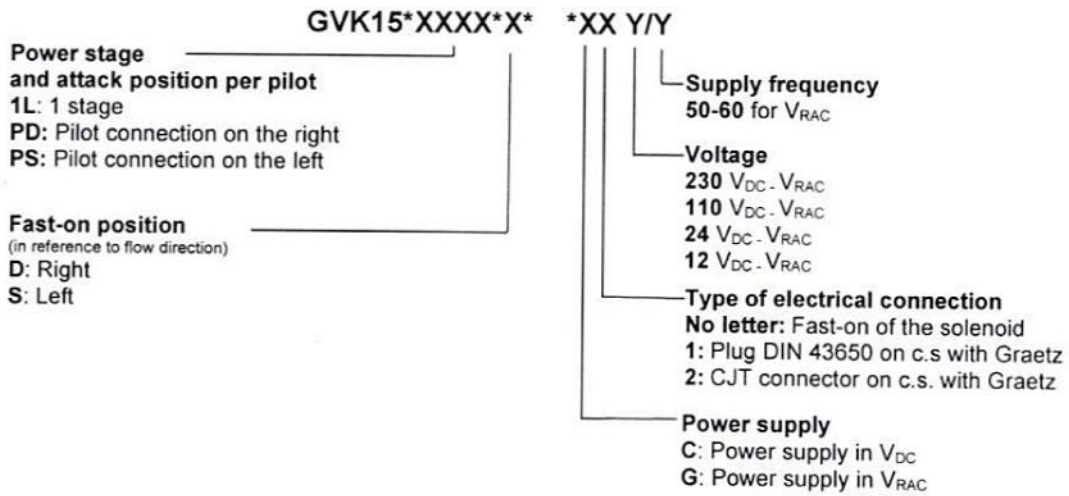

Example:

GVK15*1L*STS*G1 230/50-60

Type GVK15: solenoid valve group

Features:

1L: 1 power level

S: Orientation position of the fast-on to the left with respect to the flow direction

G: Power supplied with rectified current (V_{RAC})

1: Plug DIN 43650 on c.s with Graetz

230: Power supply voltage 230/50-60

Example:

GVK15*1LPS*C 230Vdc

Type GVK15: solenoid valve group

Features:

1L: 1 power level

PS: Pilot connection outlet on the left

C: Power supplied with direct current (V_{DC})

230: Power supply voltage 230Vdc

NOTES:

- For G version the connection box has different wiring if mounted on the left side or on the right side. Pay attention and respect the wiring label.

FLOW RATE DIAGRAM

PRESSURE DROP
mbar

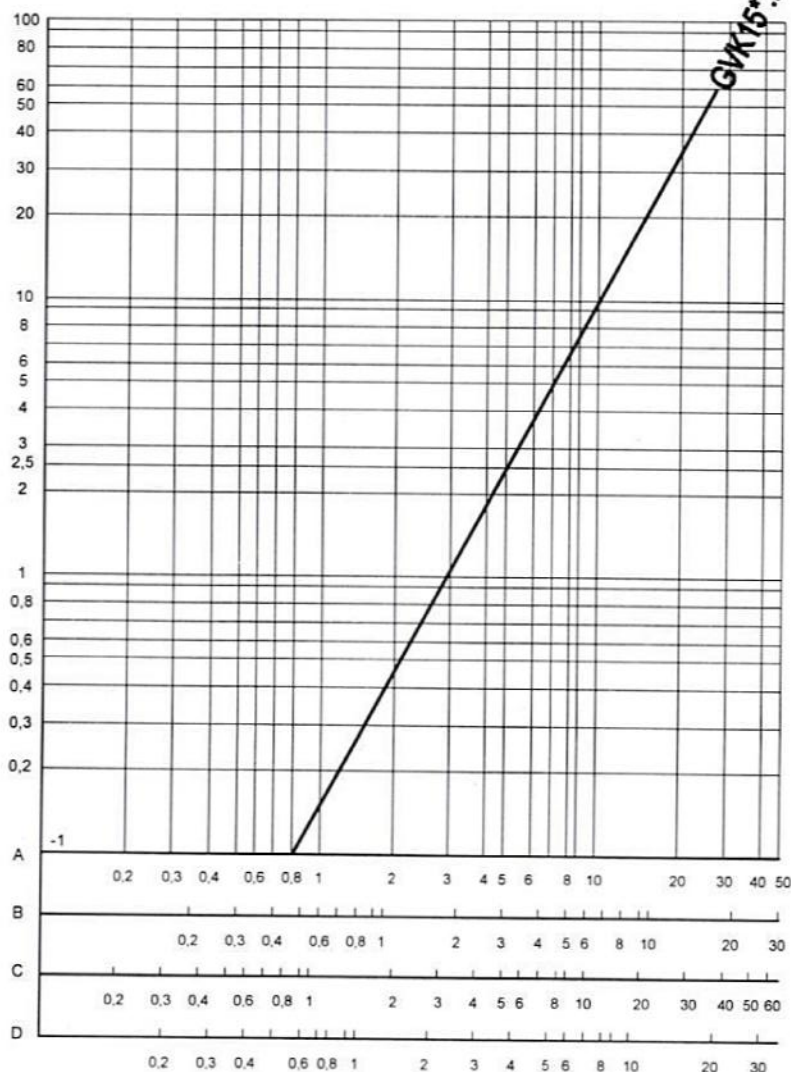

FLOW RATE
m³/h

- A : Standard flow rate m³/h of NATURAL GAS relative density 0.554
- B : Standard flow rate m³/h of LPG relative density 1.54
- C : Standard flow rate m³/h of TOWN GAS relative density 0.411
- D : Standard flow rate m³/h of AIR relative density 1



NOTES FOR PRODUCT DISPOSAL

The device contains electronic components and cannot therefore be disposed of as normal household waste. For the disposal procedure, please refer to the local rules in force for special waste.

ATTENTION → Company Brahma S.p.A. takes no responsibility for any damage resulting from Customer tampering with the device.

BRAHMA S.p.A.
Via del Pontiere, 31
37045 Legnago (VR)
Tel. +39 0442 635211 - Telefax +39 0442 25683
<http://www.brahma.it>
E-mail : brahma@brahma.it

27/01/2021 Subject to amendments without notice